



Rewarding Learning

ADVANCED SUBSIDIARY (AS)
General Certificate of Education
2023

Centre Number

--	--	--	--	--

Candidate Number

--	--	--	--

Life and Health Sciences

Assessment Unit AS 5
assessing

Material Science

[SZ051]

THURSDAY 8 JUNE, MORNING



SZ051

TIME

1 hour 30 minutes.

INSTRUCTIONS TO CANDIDATES

Write your Centre Number and Candidate Number in the spaces provided at the top of this page.

Answer **all eight** questions.

Write your answers in the spaces provided in this question paper.

INFORMATION FOR CANDIDATES

The total mark for this paper is 75.

Figures in brackets printed down the right-hand side of pages indicate the marks awarded to each question or part question.

You may use an electronic calculator.

Quality of written communication will be assessed in question 5.

For Examiner's use only	
Question Number	Marks
1	
2	
3	
4	
5	
6	
7	
8	

Total Marks	
--------------------	--

1 (a) The coefficient of friction is calculated using the equation

$$\text{coefficient of friction } (\mu) = \frac{\text{Friction (F)}}{\text{Normal Reaction (R)}}$$

where Normal Reaction = Weight

Use this information to answer the following question.

(i) A mass of weight 30 N is placed on a horizontal surface, as shown in the diagram below.

When the mass is just about to move, the frictional force is 12 N.

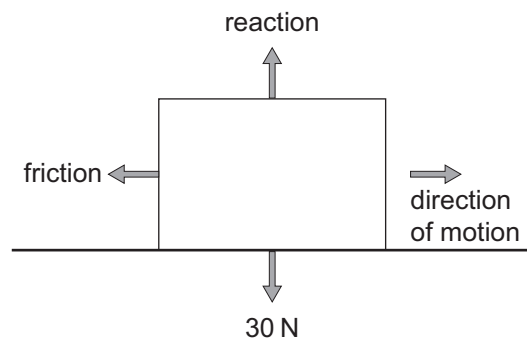

Calculate the coefficient of friction, μ , between the mass and the surface.

Coefficient of friction = _____ units [3]

(ii) Circle the correct unit for the coefficient of friction, μ .

Newton (N)

Newton per kilogram (Nkg^{-1})

No unit

[1]

Examiner Only	
Marks	Remark

- (b) Indentation hardness tests are used to determine the suitability of a material's hardness for certain applications.

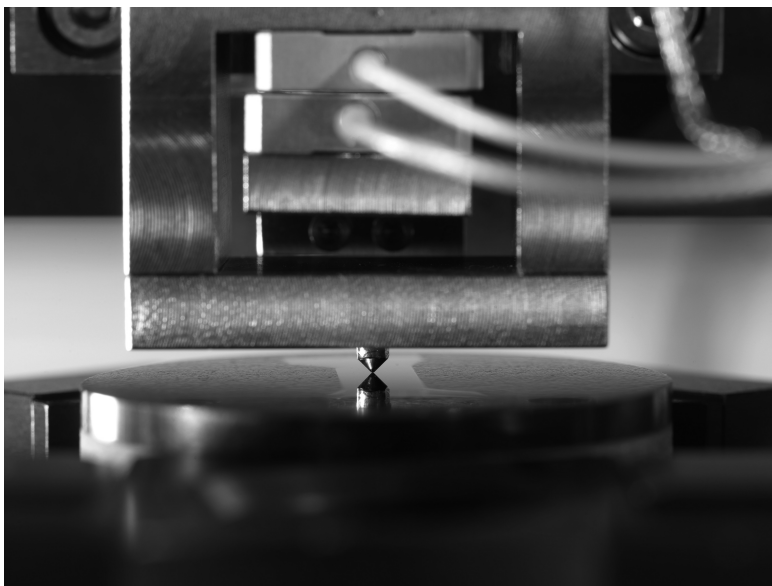

Source: © Andrew Brookes, National Physical Laboratory / Science Photo Library

- (i) Name the method which could be used to test the hardness of a sample of stainless steel.

_____ [1]

- (ii) What material is the indenter made from?

_____ [1]

- (iii) State the typical size of the force load used in this hardness test.

_____ N [1]

- (iv) For approximately how long is this force applied?

_____ seconds [1]

- (v) Suggest one other measurement that needs to be recorded?

_____ [1]

- (vi) State the equation used to calculate hardness.

_____ [1]

Examiner Only

Marks Remark

- 2 A pupil collected a set of results for an experiment carried out to determine the Young Modulus of a piece of metallic wire.

The table below includes some of the results.

Force /N	Cross-sectional area /m ²	Change in length /mm	Strain
5.50	6.16×10^{-8}	1.35	9.64×10^{-4}

In the following questions you are advised to show your working.

- (i) Calculate the original length of the wire in metres.

Original length = _____ m [4]

- (ii) Name the piece of apparatus used to measure the original length of the wire.

_____ [1]

- (iii) Calculate the diameter of the wire in millimetres.

Diameter = _____ mm [4]

Examiner Only	
Marks	Remark

(iv) Name the piece of apparatus used to measure the diameter of the wire.

_____ [1]

(v) Calculate the Young Modulus for this wire.

Young Modulus = _____ Pa [5]

Examiner Only	
Marks	Remark

3 Materials can be grouped into distinct categories such as metals, ceramics, glasses and polymers.

(a) Tick all the categories of material that are best suited to the following properties.

An example has been done for you.

Property	Category of material			
	metals	ceramics	glasses	polymers
Chemically resistant		✓	✓	✓
Good conductor of electricity				
Good thermal insulator				
Brittle				

[3]

(b) What is the difference between the structure of metals and the structure of glass?

[2]

(c) PVC is an example of a polymer.

It can be used as electrical wire insulation.

Is PVC a thermoplastic or a thermosetting plastic?

Give a reason for your answer in terms of the structure of PVC.

[2]

Examiner Only	
Marks	Remark

5 Smart materials have special features designed for specific situations.

Write an account of the features and comparisons for some smart materials.

Your answer should include:

- a definition of a smart material;
- a feature of **electroluminescent** materials;
- a comparison between **thermochromatic** materials and **photochromatic** materials;
- and the names of two **other** types of smart materials.

Quality of written communication will be assessed in this question.

Smart material definition

Feature of electroluminescent materials

Comparison between thermochromatic materials and photochromatic materials

Two other types of smart material

[6]

Examiner Only	
Marks	Remark

6 Substance **A** and substance **B** are two different materials.

They were added together to form substance **C**.

There was no reduction in volume.

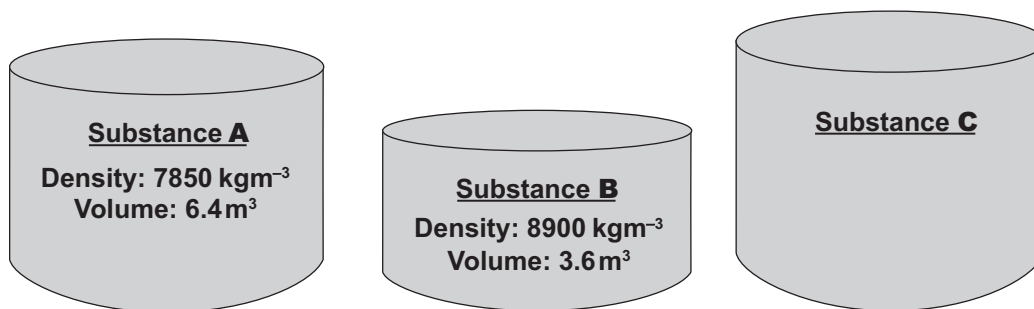

Diagrams not to scale

In the following questions you are advised to show your working.

(i) Calculate the mass of substance **C**.

Mass = _____ kg [4]

(ii) Find the density of substance **C**.

Density = _____ kgm⁻³ [3]

Examiner Only

Marks Remark

(iii) Convert your answer in part (ii) to gcm^{-3} .

Density = _____ gcm^{-3} [1]

(iv) Substance **C** is cut in half.

What effect, if any, does this have on the density?

_____ [1]

Examiner Only

Marks Remark

7 (a) State **two** of the physical properties of copper that make it suitable for use in water pipes.

1. _____
2. _____ [2]

There are several external factors that can influence the choice of materials for a particular situation. One of these is the need to follow regulations regarding Health & Safety guidance and waste disposal.

(b) State **two other** external factors and give a brief description of each.

Factor 1 _____

Description

_____ [2]

Factor 2 _____

Description

_____ [2]

Examiner Only	
Marks	Remark

BLANK PAGE
(Questions continue overleaf)

- (c) Below is a circuit diagram showing a battery with a lamp and a diode in series.

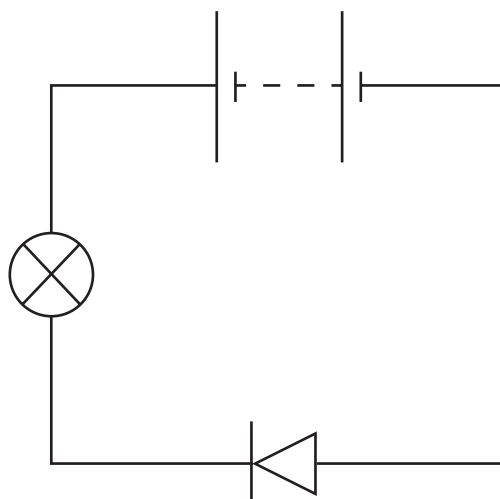

- (i) Is this diode in forward or reverse bias?

_____ [1]

- (ii) In terms of the depletion layer, describe what is happening when the battery is connected.

 _____ [3]

THIS IS THE END OF THE QUESTION PAPER

Examiner Only

Marks	Remark

Permission to reproduce all copyright material has been applied for.
In some cases, efforts to contact copyright holders may have been unsuccessful and CCEA
will be happy to rectify any omissions of acknowledgement in future if notified.